

Troubleshooting

The load will not switch on:

- The LUX adjuster is set too low and is inhibiting the switch.
- The moving body is not emitting more IR than the background.
(Person wearing insulating clothing in a warm environment)
- Person is too far from the HB PIR (xx) SV switch, see detection diagram.
- Person is moving unusually slowly (perhaps when testing).

The load switches on when nobody is present:

- Heater causing infra-red variations in a small cold room.
Re-site the HB PIR (xx) SV s.
- Please contact DANLERS for further technical support.

Momentary switches

DANLERS can supply a range of Momentary/Retractive switches - push to make or break:

MOMSW MP - Plated grey metal finish with PRESS preprinted on switch.

MOMSW M - Plated grey metal finish with blank switch.

MOMSW WHP - Plated white finish with PRESS preprinted on switch

MOMSW WH - Plated white finish with blank switch.

MOMSW PMOD - Grid module suitable for MK Grid Plus with PRESS preprinted on switch.

MOMSW MOD - Grid module suitable for MK Grid Plus with blank switch.

Precautions and Warranty

This product conforms to BS EN 60669-2-1. Product complies to Class 2 insulation.

Please ensure the most recent edition of the appropriate local wiring regulations are observed and suitable protection is provided e.g. 6 amps over current, 1kV over voltage. Please ensure that this device is disconnected from the supply if an insulation test is made.

This product is covered by a warranty which extends to 5 years from the date of manufacture.

Products available from DANLERS

- PIR occupancy switches • Daylight linked dimmers • Manual high frequency dimmers
- Photocells • Radio remote controls • Time lag switches • Outdoor security switches
- Dimmers • Heating, ventilation and air-conditioning controls • Bespoke / O.E.M. products

Please call for more information or a free catalogue, or visit our website.

DANLERS Limited, Vincients Road, CHIPPENHAM, Wiltshire, SN14 6NQ, UK.

Telephone: +44 (0)1249 443377 Fax: +44 (0)1249 443388

E-mail: sales@danlers.co.uk Web: www.danlers.co.uk

Company Registered Number 2570169 VAT Registration Number 543 5491 38



High bay PIR occupancy switches with short visit / exit mode

HB PIR ND SV

HB PIR SP SV

HB PIR WD SV

DANLERS high bay passive infra-red occupancy switches with short visit / courtesy exit mode can be mounted directly onto solid ceilings or onto a range of different mounting boxes. To operate the short visit function a momentary (retractive) wall switch is required.

They incorporate a passive infra-red quad sensor to detect movement of a warm body within their detection zone (diagram B) and a photocell to monitor the ambient light level.

Upon detecting movement, if the ambient light is dark enough, the HB PIR (XX) SV will turn the load on. The ambient threshold can be set by the user to between approximately 30 lux and 1000 lux and maximum (photocell inactive) at the HB PIR (XX) SV via the LUX adjuster (diagram A).

If no more movement is detected within a pre-selected time, then the control will turn the load off. This time lag can be set via the TIME adjuster to 10 seconds, 20 seconds, 40 seconds, 80 seconds, 2 minutes 30 seconds, 5 minutes, 10 minutes, 20 minutes or 40 minutes (diagram A).

SHORT VISIT MODE: If you are visiting a room for a short time you can operate the wall switch. The lights will then just stay ON for just 30 seconds before switching OFF and does not stay on for the rest of its set time lag. After 30 seconds, any other detected movement will bring the lights ON again, for the regular set time lag.

COURTESY EXIT MODE: This can also switch lights OFF before the regular time lag has elapsed. If you press the wall switch when you leave, the lights will remain ON for 30 seconds for you to vacate, and then switch OFF. Any other detected movement after the 30 seconds will bring the lights back ON for the regular set time lag.

These high bay controls are available in three types - each with a particular detection pattern which is optimised for particular applications.

HB PIR ND SV: Narrow Detection version is ideal for covering storage aisles.

HB PIR SP SV: Spot Detection version is ideal for smaller areas, such as the entrances to storage aisles.

HB PIR WD SV: Wide Detection version is ideal for large open areas, such as factories, sports halls and entrance halls.

Loading

The switch should only be connected to a 230V 50Hz AC supply.

These PIR switches can switch up to:

6 amps (1500W) of resistive loads.

6 amps (1500W) of fluorescent loads.

3 amps (750W) of electronic and wire wound transformer loads.

2 amps (500W) of CFL, 2D lamps, LED Drivers and LED lamps and fittings.

1 amp (250W) of fans

Minimum load 2W resistive, suitable for most energy saving lamps, LEDs and emergency fittings.

Installation procedure

- Please read these notes carefully before commencing work. In case of doubt please consult a qualified electrician.
- POSITIONING:** The PIR occupancy switch (PIR) should be installed to achieve correct coverage of the area, see diagram B. If the photocell override facility is required, the switch must be located above an area where daylight can give greater illumination than the artificial light. Avoid locating this product where it is exposed to drafty conditions (exposed lobbies, open ceiling voids or near fans) or near heat sources. To cover large areas PIRs should be spaced in a 5 metre grid formation.
- The greatest energy savings will be achieved if each PIR controls an independent set of lamps. They can be wired in parallel but this should ideally be limited to three, see diagram D.
- Make sure the power is isolated from the circuit. The PIR should be connected as shown in diagrams C & D:
L - Live in. N - Neutral in. SW¹/AB - Switch input. SL - Switched Line out.
Terminate the mains cable with the supplied terminal block (terminal blocks must comply with EN 60998-1 or EN 60998-2-1 and be suitable for 0.75- 1.5mm² conductors). In order to comply with wiring regulations, the terminal block must be enclosed in a suitable wiring box (This should comply with EN 60670-1 or EN 60670-22).
- Knockout or drill the appropriate holes on the mounting plate (See diagram E) for attaching the plate to the ceiling or back box (if applicable). Feed cables through the appropriate (side or rear) entry hole. Screw the back mounting plate to the ceiling or back box via the mounting holes. Wire the cables into the sensor head block terminal. Push the sensor head onto the mounting plate and align the side clips with the slots on the sensor heads.

Start-up mode

When the PIR is powered up, the PIR will switch on the lighting load for 1 minute then switch it off. After 2 seconds it will switch on again if it detects movement. With Time set to minimum the load will stay on for 10 seconds so the detection range can be easily assessed. If a manual override-off switch is positioned before the PIR in the circuit (diagrams C & D, note 1) it will do this each time the wall switch is switched on. Alternatively, if the wall switch is placed after the PIR (diagrams B & C, note 2) it will not enter the start-up mode each time.

Time and Lux set up

For convenience, ensure that the TIME is set to the minimum when setting up the LUX level. Afterwards set the TIME to a value suitable for the application, making reference to diagram A.

The LUX is best set up when the local ambient light is at approximately the minimum desired working light level, a lux meter placed on the surface under the PIR may help. With the LUX set fully clockwise wait for the PIR to switch off. Rotate the LUX adjuster slowly anticlockwise (- to +), whilst waving your hand approximately 1m below the PIR, until the load switches on.

A: Adjusting time and lux

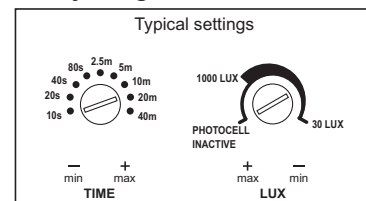

B: Detection diagrams

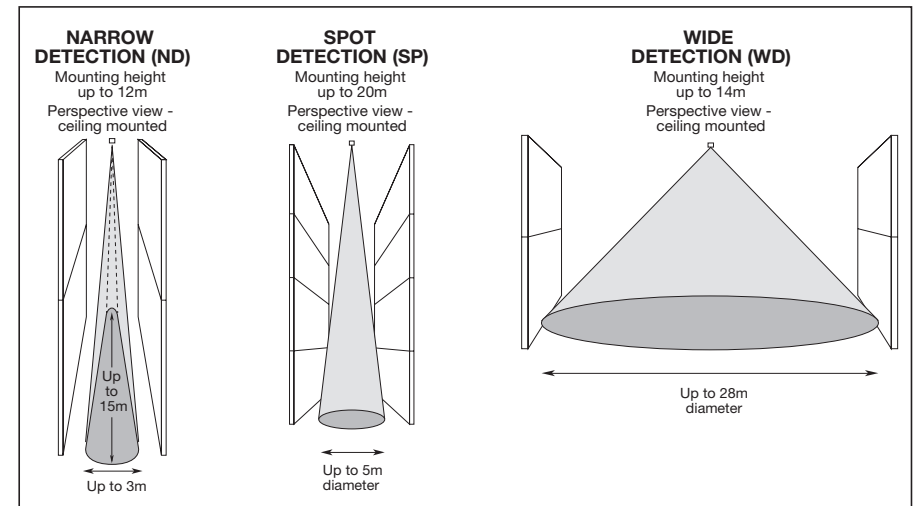

C: Wiring diagram, single PIR

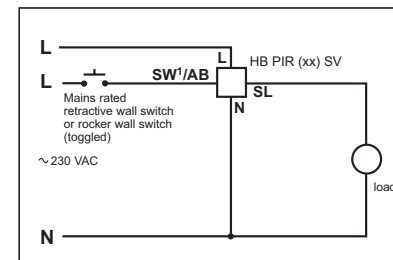

D: Wiring diagram, multiple PIRs

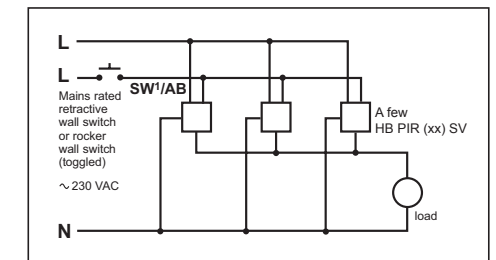

E: Mounting plate fixing

